

# FÉDÉRATION INTERNATIONALE DE L'AUTOMOBILE

## COMMISSION INTERNATIONALE DU KARTING

### Scheda di Omologazione 1973-1974

#### Fiche d'Homologation

### MOTORE PER KART - CATEGORIA 100 cc INTERNAZIONALE

#### Moteur pour Kart - Catégorie

Casa Costruttrice  
*Constructeur*

IAME S.p.A.

Modello  
*Modelle*

PARILLA TT22

Anno inizio fabbricazione  
*An de production*

1972

L'omologazione è valida da:  
*L'homologation est valide dès*

1° GENNAIO 1973

FÉDÉRATION INTERNATIONALE
RE-HOMOLOGATION
N° FIA/CK 3 / 03
DE L'AUTOMOBILE F.I.S.A.

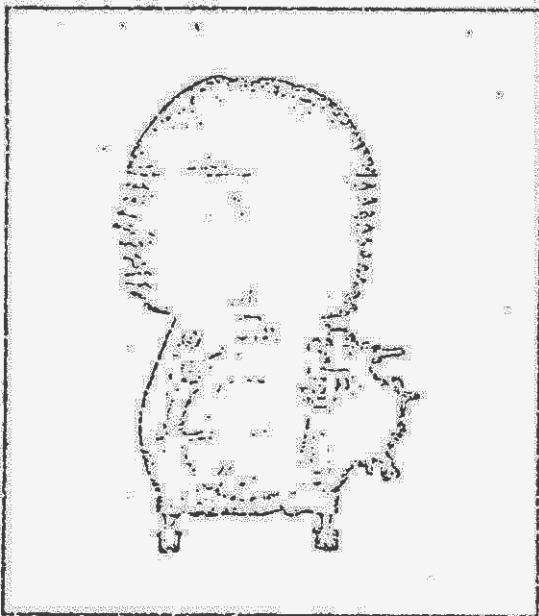

1. Fotografia del motore visto dal lato comando  
*Photo moteur côté pilote*

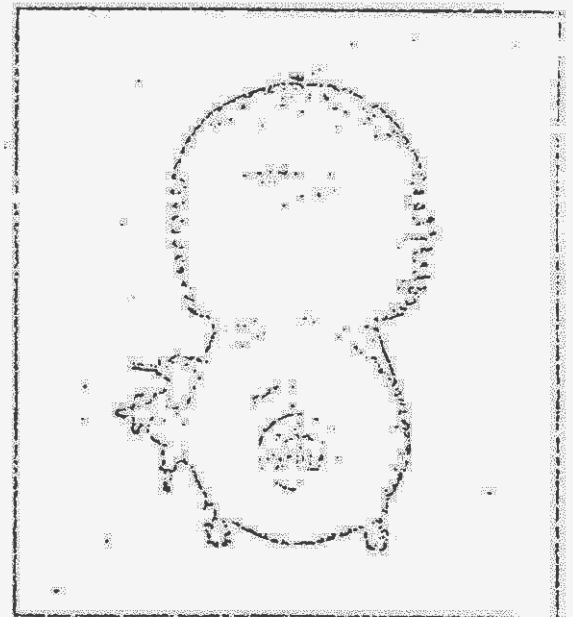

2. Fotografia del motore visto dal lato opposto al comando  
*Photo moteur côté opposé*

N pagine che compongono la scheda &  
*N. pages composant la fiche*

Timbro della C.S.A.I.  
*Timbre de C.N.K.*

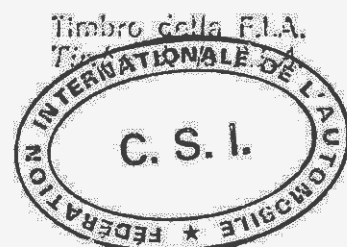

Modello: DELL'ORTO MB 24A - BING - TILLOTSON  
 (type, make, type, diameter of distributor)  
 (type, make, type, diameter of choke)

Alimentazione: DISTRIBUTORE ROTATIVO  
 (type)  
 (type)

Pistone: a 3 LUCI - MARCHE VARIE - 1 - PESO GR. 95 circa  
 (Piston)  
 (Piston)

Segmenti: n. 11 o 11+1 AC      dimensioni: 2x2 e 2x1,9 o 2x1,5  
 (Segments - number)              (dimensions)  
 (Rings - number)                    (dimensions)

Corsa mm. 53,8                      Alesaggio mm. 43,2  
 Cilindrata 93,25 cc                Alesaggio massimo mm. 42,64

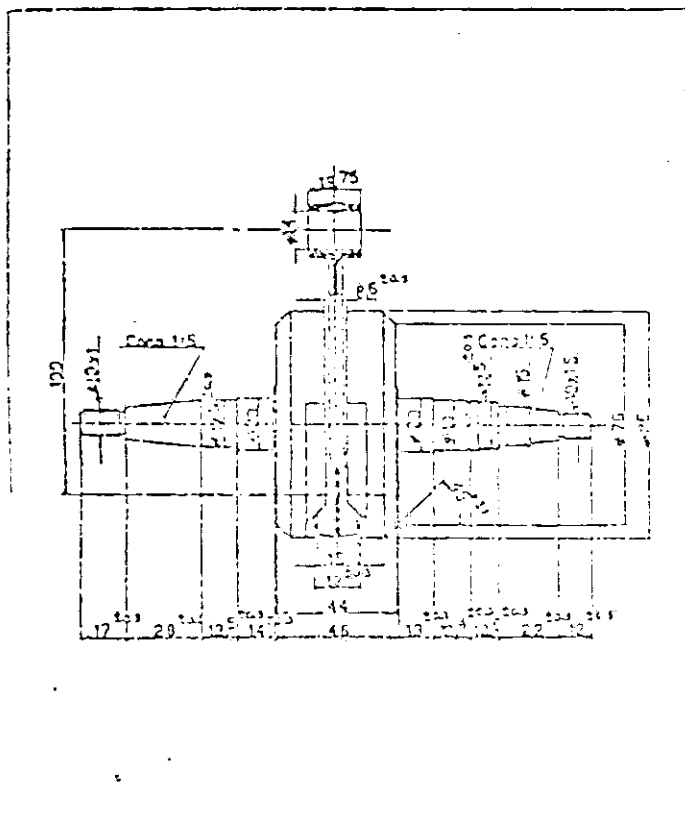
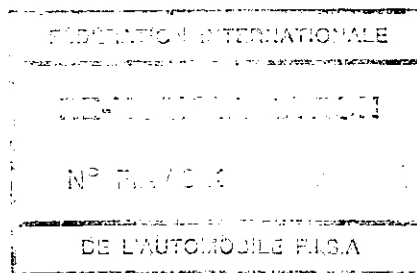

Albero motore e biella

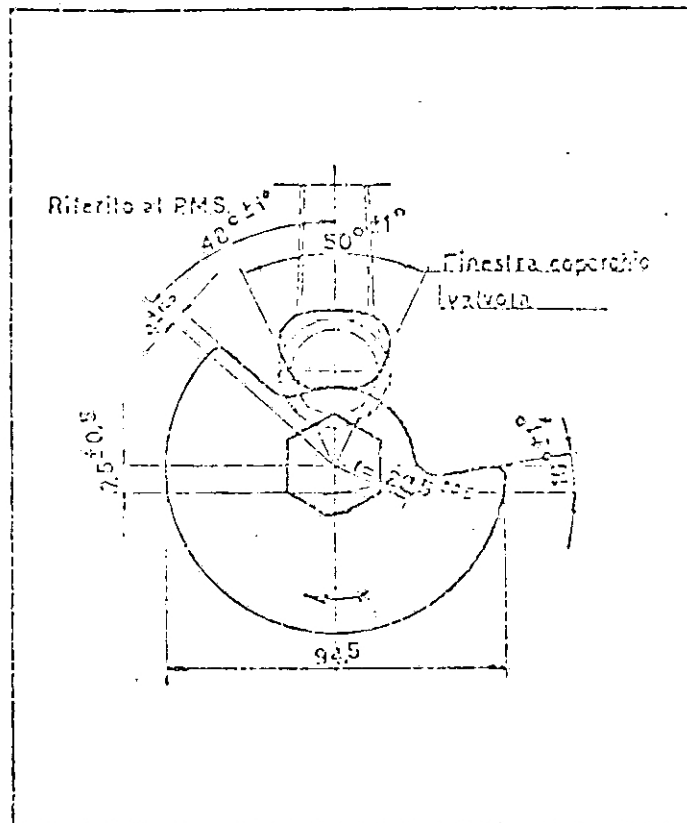

Disco distributore

cuscinetti di banco  
 (bushings)  
 (bearings - of crankshaft)

tipo: A SFERE o RULLI  
 (type)  
 (type)

dimensioni: 20x47x14  
 (dimensions)  
 (dimensions)

testa biella:  
 (big end of connecting rod)

tipo: A RULLI  
 (type)  
 (type)

dimensioni: 3x11,8  
 (dimensions)  
 (dimensions)

piede biella:  
 (small end of connecting rod)

tipo: A RULLI oppure a BRONZINA  
 (type)  
 (type)

dimensioni: 2x13,2 oppure 14x19,75  
 (dimensions)  
 (dimensions)

raffreddamento: AD ARIA - LIBERO  
 (cooling)  
 (cooling)

Peso del motore con accessori: KG. 13 circa  
 (weight)  
 (weight)

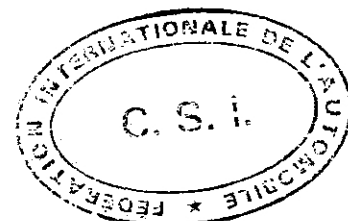

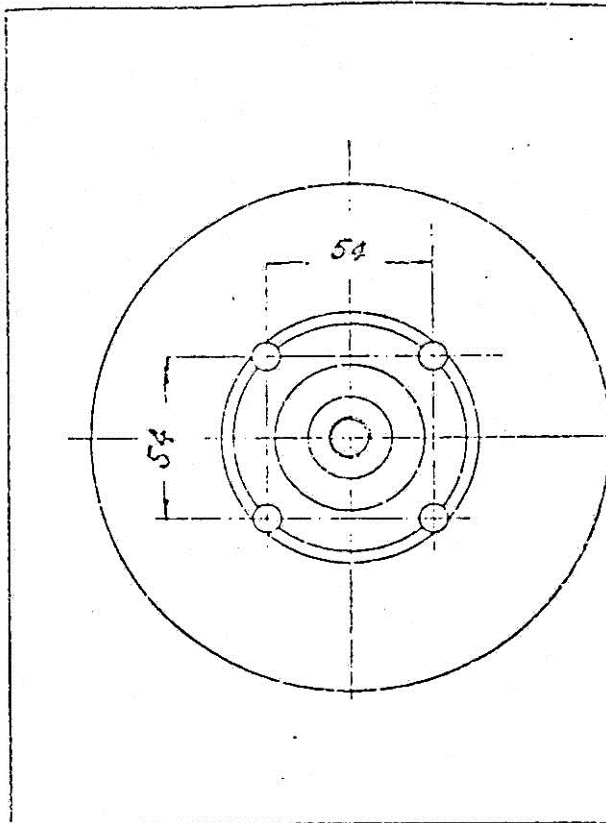
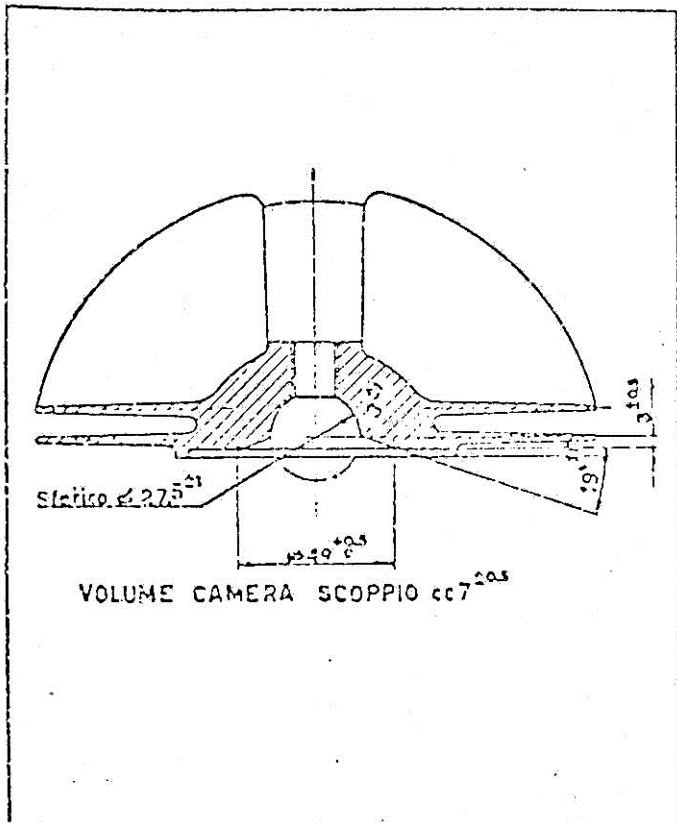

Materiale: ALLUMINIO FUSO

Peso: KG. 1,350 circa

FEDERATION INTERNATIONALE  
 RE-IMBLOCCATION  
 N° FIA/CIK 83/03  
 DE L'AUTOMOBILE F.I.S.A

CILINDRO

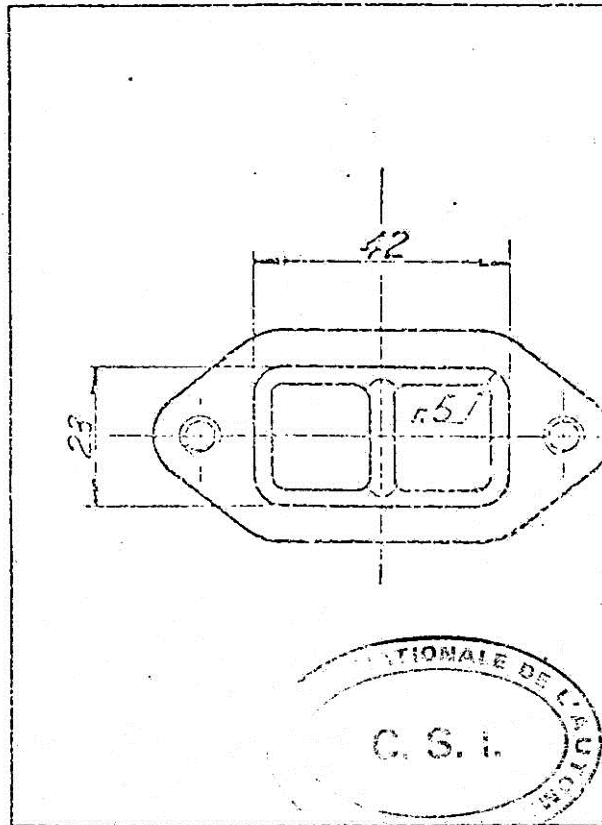
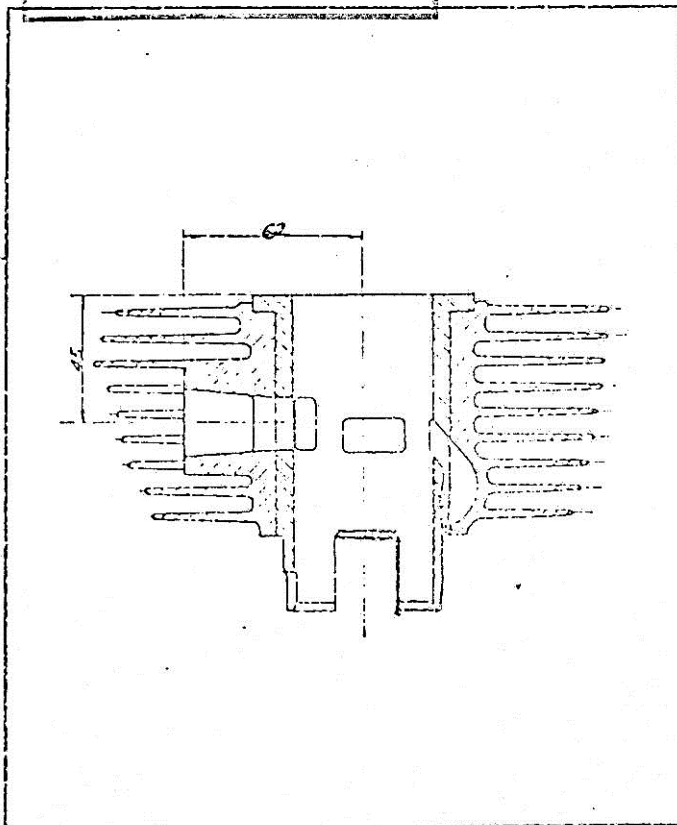

Materiale: ALLUMINIO - GHISA - CROMO

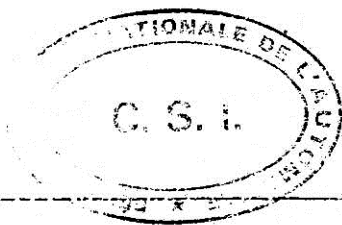

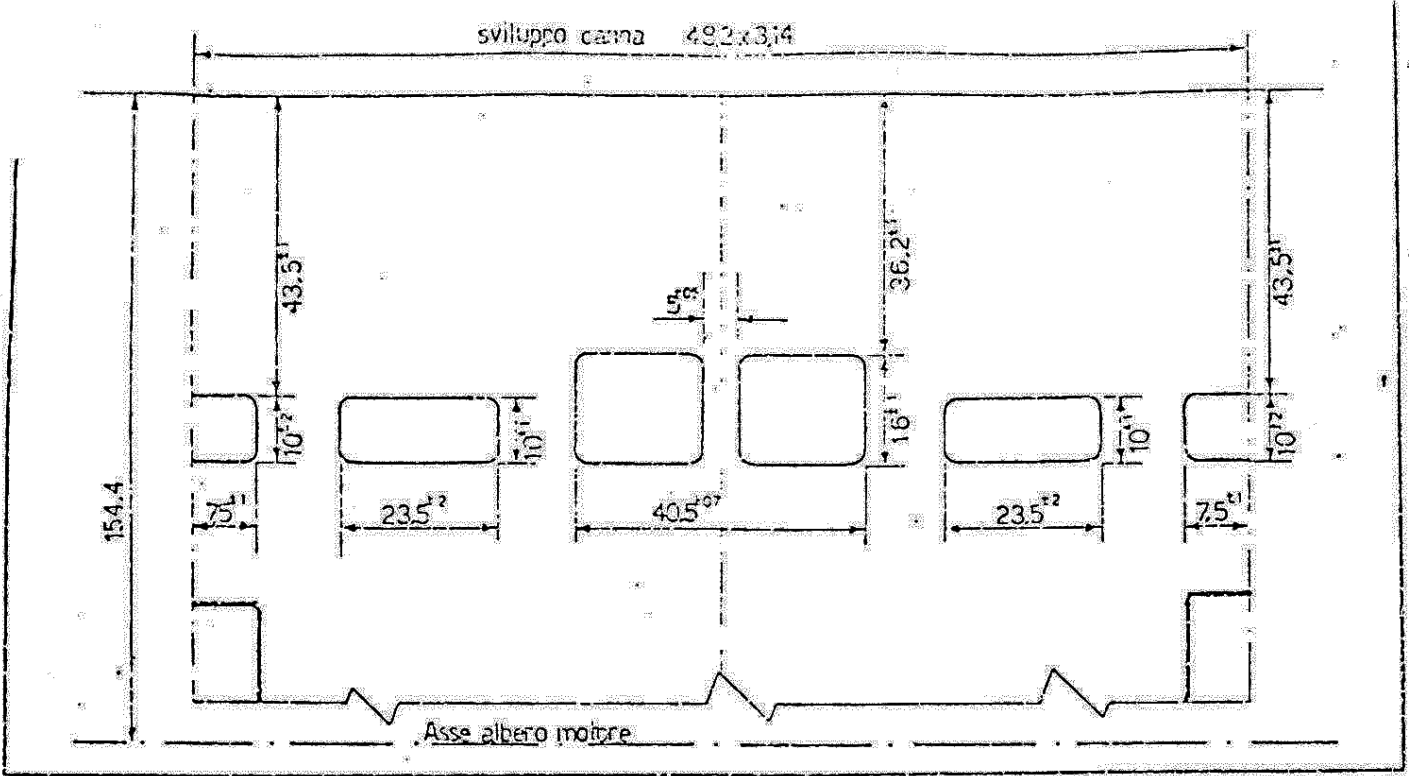

Materiale: GHISA-CROMO

Peso: Kg. 2,350

BIELLA

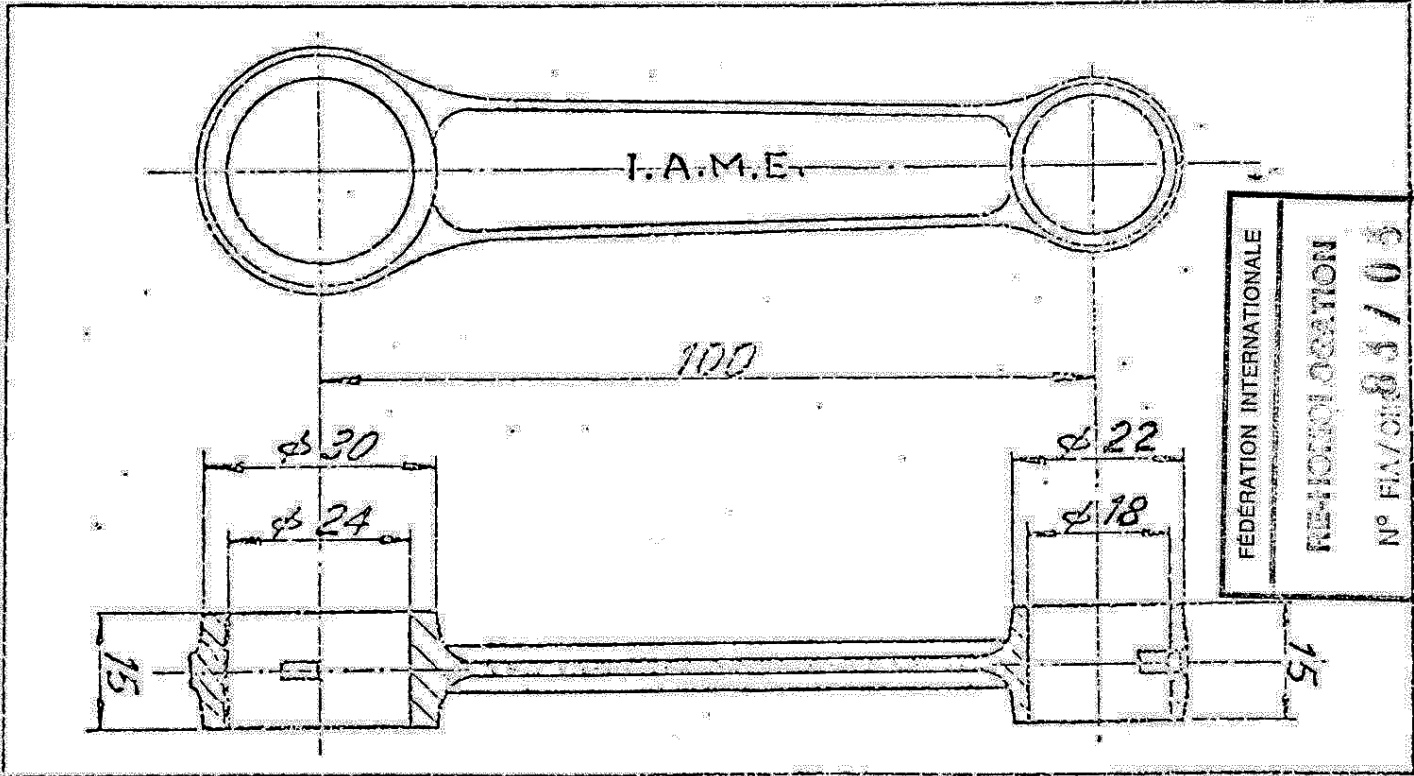

Materiale: ACCIAIO

Peso: 115 GRAMMI circa

BASAMENTI

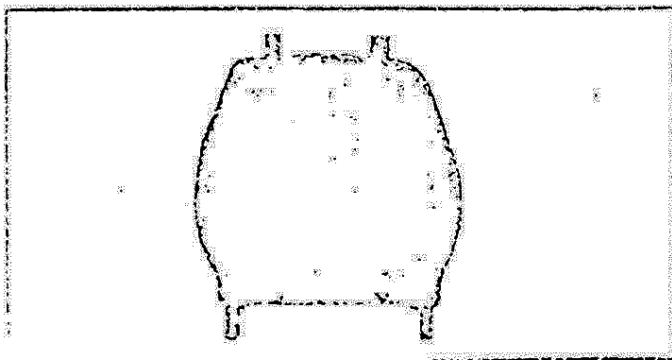

ALIMENTAZIONE

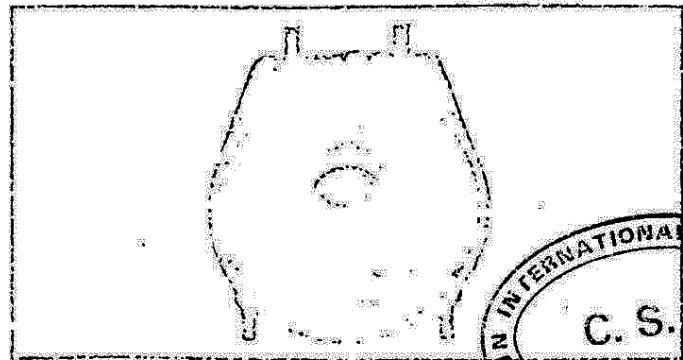

# FEDERATION INTERNATIONALE DE L'AUTOMOBILE

COMMISSION INTERNATIONALE DU KARTING

**EXTENSION A LA FICHE  
D'HOMOLOGATION:**

**HOMOLOGATION 1973 - 1974**

**MOTEUR POUR KART CATEGORIE 100 CCM**

Constructeur: **I.A.M.E. S.p.A. - ZINGONIA - ITALY**

Modèle: **PARILLA TT 22**

FEDERATION INTERNATIONALE
RE-HOMOLOGATION
N° F.I.A./C.M. 03/03
DE L'AUTOMOBILE F.I.S.A.

Nombre de pages: **1**

L'extension est prononcée à compter du: **- 1. Feb. 1979**

(à remplir par la F.I.A.)

## Descriptions (remarques)

### Pag. 2

Albero motore = Variato diametro filetto terminale

Vilebrequin = Variation des filets d'extrémité

### Pag. 3

Sezione cilindro = Vista corretta del 3° travaso

Section cylindre = Vue correcte du 3ème transfer

Base cilindro = Variato base da quadra in rotonda

Base cylindre = Variation de la base en ronde



voir verso

Dessin ou photo de la pièce:

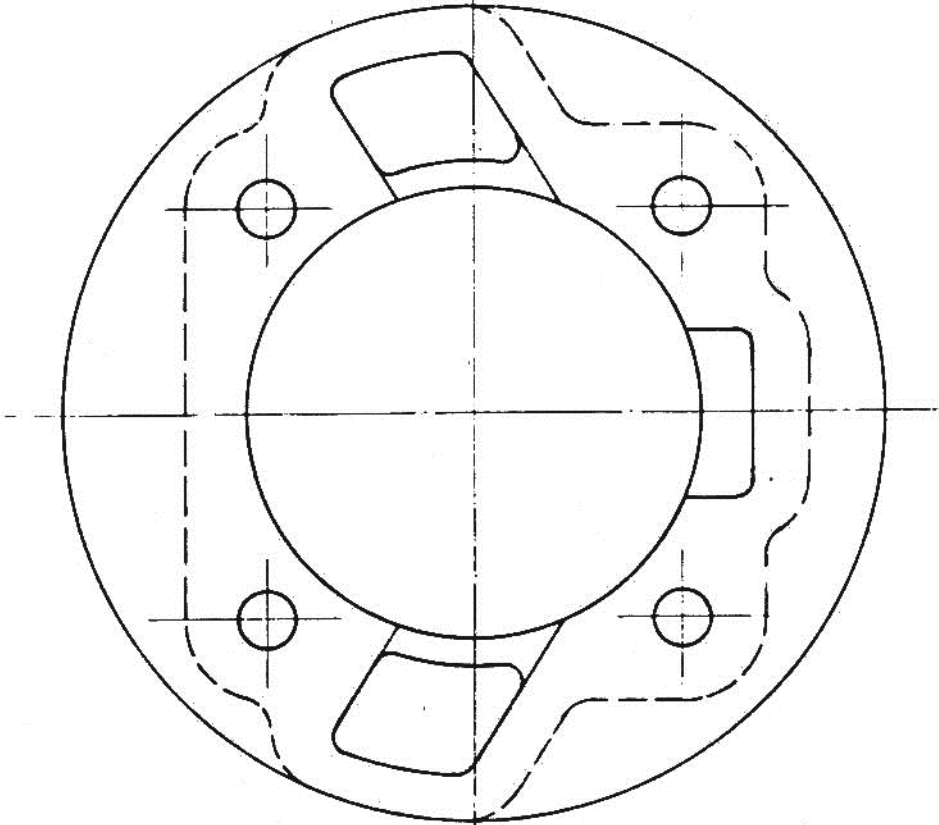
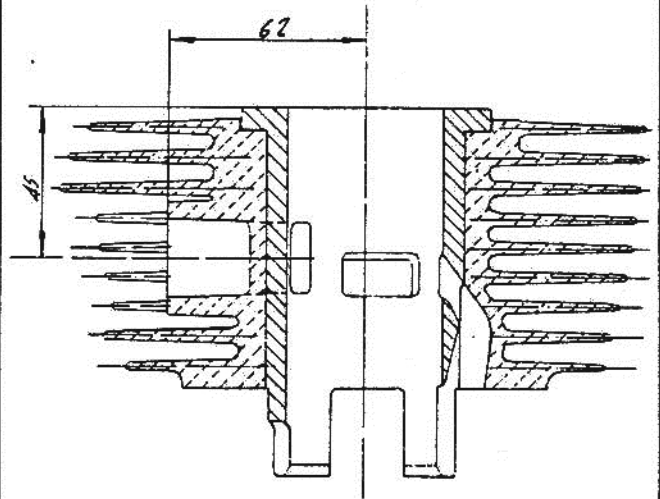
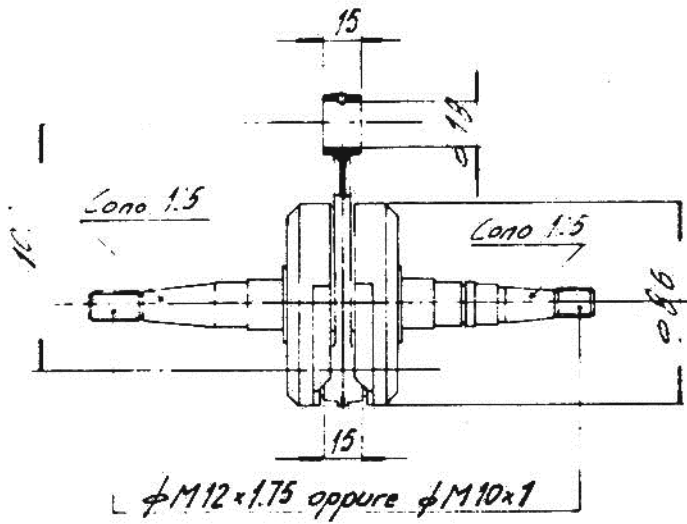

Timbre de l'Autorité Sportive Nationale



Timbre de la F.I.A.

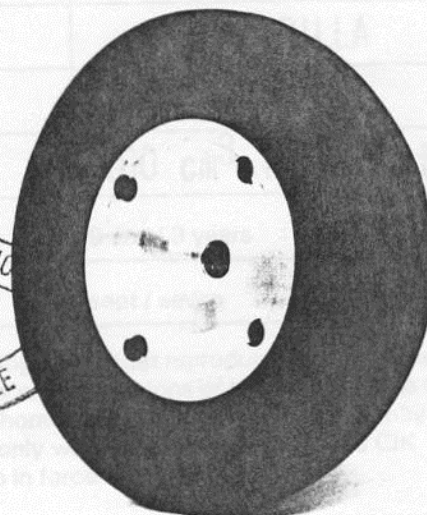
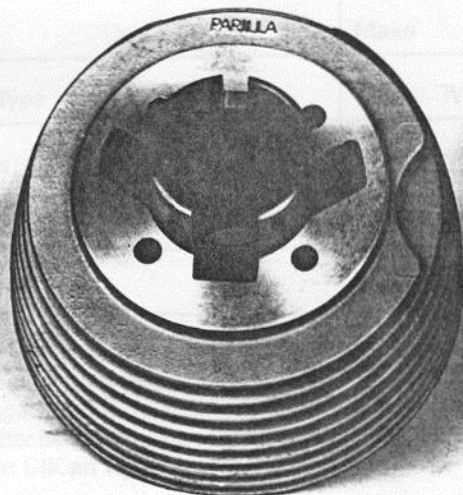

PHOTO DU PIED  
DU CYLINDRE

PHOTO OF THE BASE  
OF THE CYLINDER

PHOTO DE LA CHAMBRE  
DE COMBUSTION

PHOTO OF THE  
COMBUSTION CHAMBER



FEDERATION INTERNATIONALE  
F.I.S.A.  
DE L'AUTOMOBILE

PHOTO DU CARTER  
(FACE DE JOINT)

PHOTO OF THE SUMP  
(GASKET FACE)

PHOTO D'UNE PARTIE  
INTERIEURE DU CARTER

PHOTO OF A PART OF  
THE SUMP'S INTERIOR

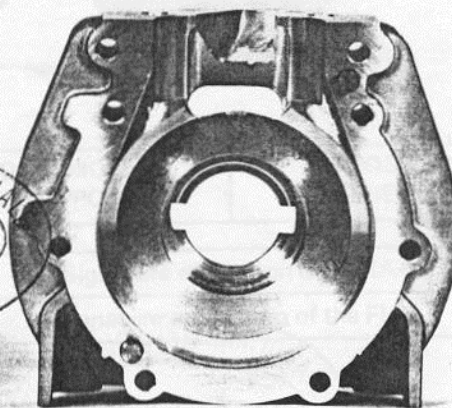
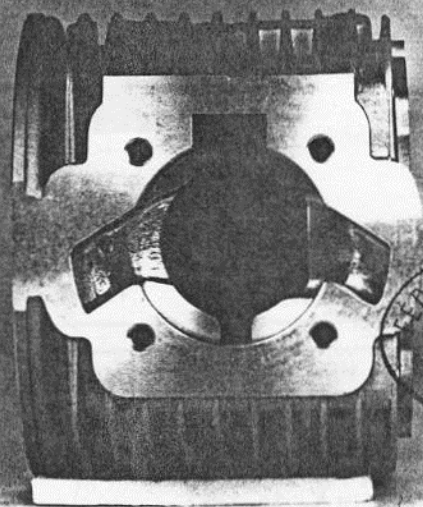

FEDERATION INTERNATIONALE  
F.I.S.A.  
DE L'AUTOMOBILE

*Handwritten signature and scribbles at the bottom left corner.*

*Handwritten signature and scribbles at the bottom right corner.*

Dessin ou photo de la pièce:

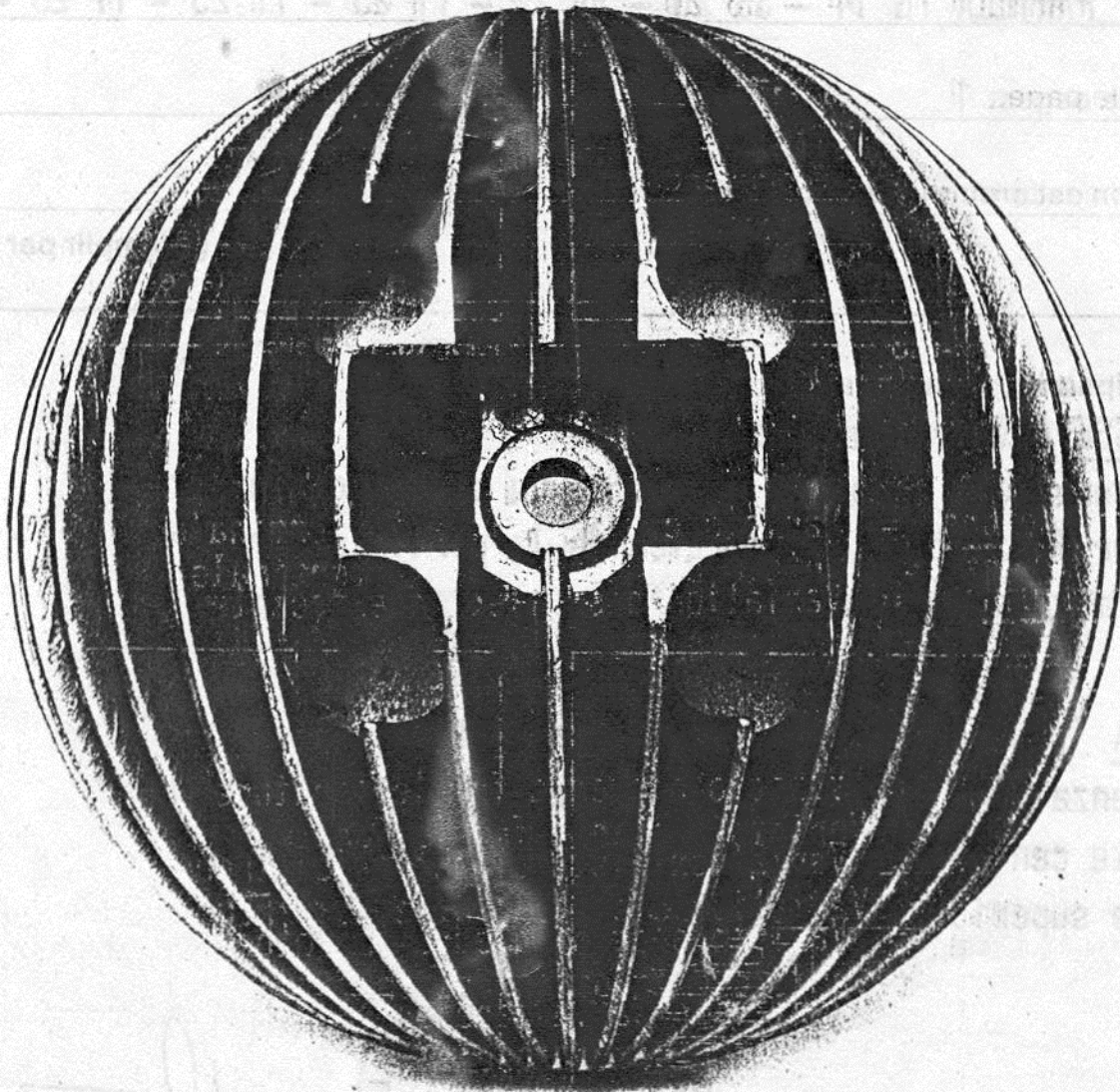
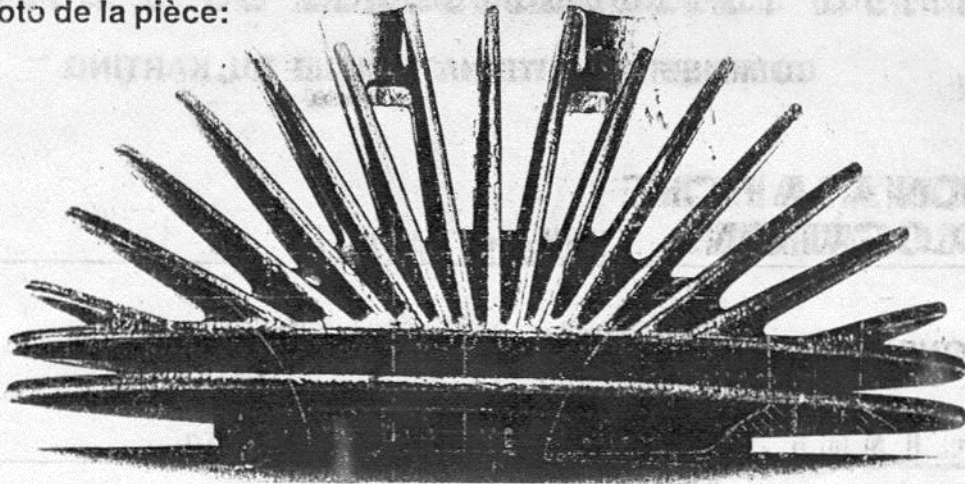

Timbre de l'Autorité Sportive Nationale

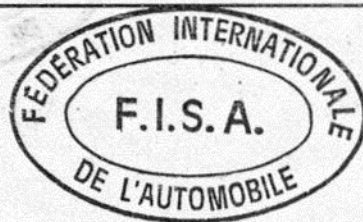
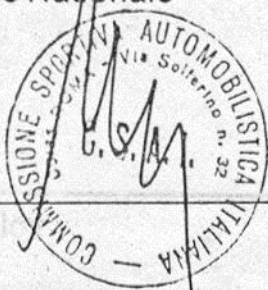

Timbre de la F.I.A.

*B. M. M. M.*